



10

ALU e PVC
ALU y PVC



araújo&silva
ferramentas de corte

JÁ MEDIU A SUA PRODUTIVIDADE?



A Araujo&Silva, Lda. desenvolve ferramentas especiais, proporcionando aos seus clientes as soluções mais rentáveis.



araújo&silva
ferramentas de corte

ESPECIALISTAS EM FERRAMENTA DE CORTE

www.araujosilva.pt



HW · MEC

D	B	d	Z
70	5	32	8
	6	32	8
72	5	32	8
	6	32	8
74	5	32	8
	6	32	8
80	5	32	8
	6	32	8
98	5	32	10
	6	32	10
100	5	32	10
	6	32	10
110	5	32	12
	6	32	12
112	5	32	12
	6	32	12
114	5	32	12
	6	32	12
70	6	32	12
72	6	32	12
74	5	32	12
	6	32	12
80	5	32	12
	6	32	12
98	5	32	12
	6	32	12
100	5	32	12
110	5	32	16
	6	32	16
112	5	32	16
	6	32	16
114	5	32	16
	6	32	16



10

ALU e PVC · ALU y PVC

* ARTIGO LIMITADO AO STOCK EXISTENTE

* Hasta fin stock

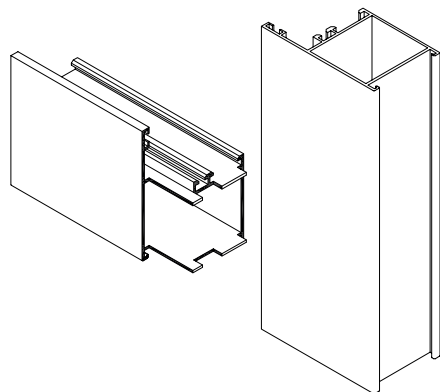



A pedido Fresas para contra-perfil (alu)
Fresas para contramoldura (alu)



HW · MEC

Nr.	D	B	d	Z
1	100	7,5	32	8
2	100	7,5	32	8
1+2				
1	120	15	32	6
2	120	15	32	6
1+2				
1	120	15	32	6
2	120	15	32	6
1+2				

* ARTIGO LIMITADO AO STOCK EXISTENTE

* Hasta fin stock

10

ALU e PVC · ALU y PVC

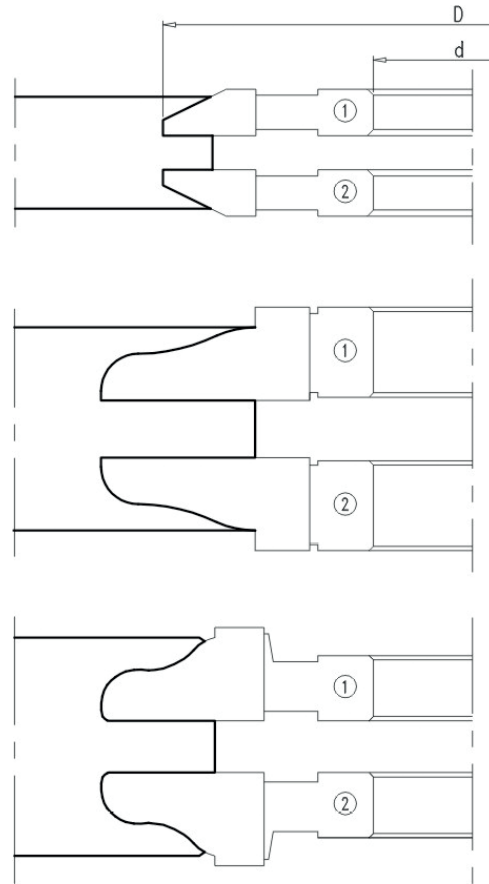



HS

D	L2	L1	S	Z	Ref.
5	12	60	8	1	3800.005.012.08
6	14	60	8	1	3800.006.014.08
8	16	60	8	1	3800.008.016.08

HS

D	L2	L1	S	Z	Ref.
5	16/45	90	8	1	3800.005.316.08
6	16/45	90	8	1	3800.006.316.08
8	14/68	100	8	1	3800.008.314.08

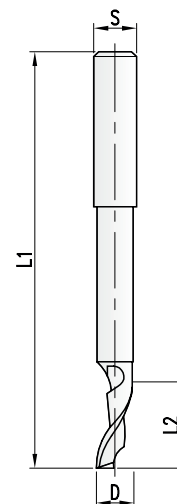
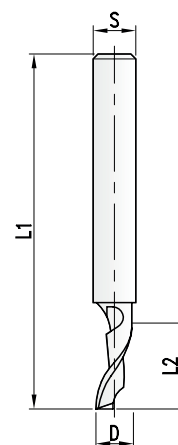

Fresa para furar e copiar em HW integral 3801
Fresa para furar e copiar em HW integral

HW

D	L2	L1	S	Z	Ref.
3	12	50	3	1	3801.003.012.03
4	12	60	4	1	3801.004.012.04
5	20	60	5	1	3801.005.020.05
6	20	60	6	1	3801.006.020.06
8	20	60	8	1	3801.008.020.08
10	25	75	10	1	3801.010.025.10

HW

D	L2	L1	S	Z	Ref.
5	20/35	70	8	1	3801.005.320.08
6	20/35	70	8	1	3801.006.320.08
8	20/35	80	8	1	3801.008.320.08
10	20/75	100	10	1	3801.010.320.10
12	20/75	100	12	1	3801.012.320.12

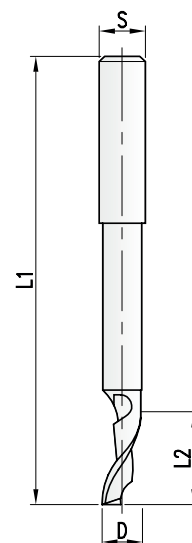
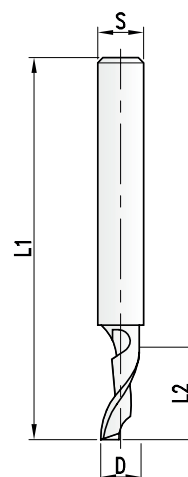



A pedido Brocas para furos escalonados

Brocas bidiastrales

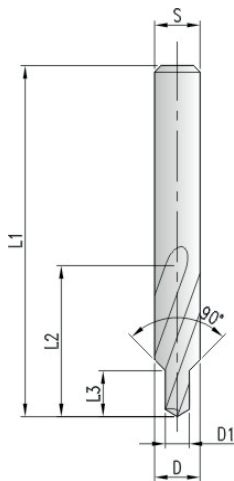

HS

D1	D	L3	L2	L1	
3,4	6,6	9	63	101	M3
4,5	9,0	11	81	125	M4
5,5	11,0	13	94	142	M5
6,6	13,0	15	101	151	M6
9,0	17,2	19	130	191	M8
10,5	19,0	23	135	198	M10

A pedido Mangas de aperto

Tubos con tuerca

10
ALU e PVC · ALU y PVC

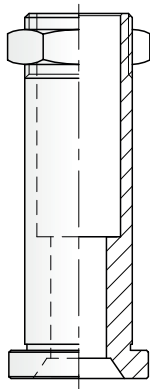
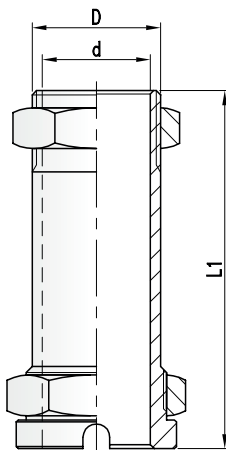

HS

D	L	d	Máquina	Modelo
32	140	27	TEKNA	TK610/Z
32	90	14	AYUTOR	500
27	90	14		MN-75-AR
32	90	14		MN-75-AR
50	85	40	ELUMATEC	AF-221, AF-222, AF-223
32	75	20	MAQUICÔA	MA-91
32	160	25	IM/CRS	OL - 94
32	100	27	TRE-C	INTEX 2500
32	150	27	LGF	BEBA
32	140	25		DIXI(Old)
32	200	25		DIXI(New)
32	156	19	MADAF	PHANTON - M
32	163,5	25		PHANTON - SK
32	150	27	MECAL	FR 704, FR 706 FR 702, FR 703 FR 712
32	125	22	MIEPA	MP - 130
32	135	27		ML - 124/OS
32	135	27	OMC	FEROCE, FEROCE-A, MÁXIMA, TIGRA, TIGRA-A
32	135	27	OMGA	AL - 132
32	135	27	PERTICI	ML - 120
32	135	27	RINALDI	LILIPUT 9M 7000 FS
32	140	27	TEKNA	TK-610-Z
32	70	14	TRIPERCISÃO	FV-100-M
22	70	14		FV-100-M
32	150	24		FV-140
32	173	25		FV-190-A
32	140	25	GREENMAC	GM 459

MANGAS DE APERTO PARA OUTRAS MÁQUINAS E MODELOS A PEDIDO. NA ENCOMENDAS INDICAR MÁQUINA E MODELO.

Tubos para otras máquinas sobre pedido. Al pedido indicar máquina y modelo



HS

d	B	D	Ref.
22	0,1	32	5075.49
	0,2	32	5075.50
	0,5	32	5075.51
	1	32	5075.52
	3	32	5075.53
	5	32	5075.54
	7	32	5075.55
	10	32	5075.56
27	0,1	37	5075.57
	0,2	37	5075.58
	0,5	37	5075.59
	1	37	5075.60
	3	37	5075.61
	5	37	5075.62
	7	37	5075.63
	10	37	5075.64
32	0,1	42	5075.65
	0,2	42	5075.66
	0,5	42	5075.67
	1	42	5075.68
	3	42	5075.69
	5	42	5075.70
	7	42	5075.71
	10	42	5075.72
	20	42	5075.73
	50	42	5075.74

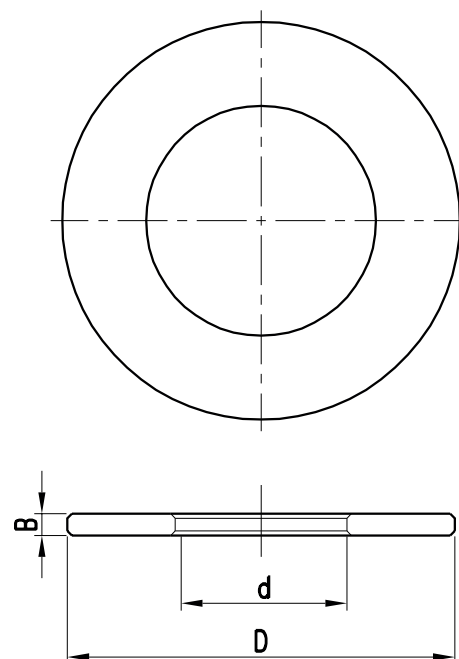

Fresas para PVC
Fresas para PVC

A pedido

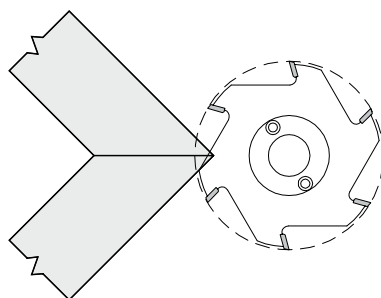
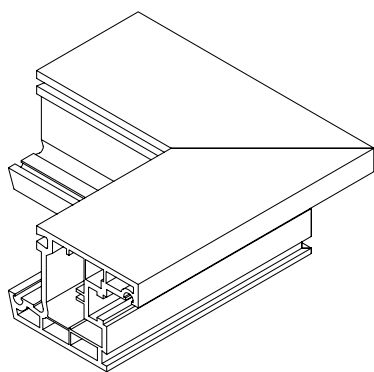

FRESAS PARA LIMPEZA DE SOLDADURA (PRODUÇÃO A PEDIDO).
PARA ELIMINAR O REBORDO OU CORDÃO DE SOLDADURA NOS AROS E FOLHAS EM PVC.
PERFIS COMPENSADOS A 45° E ADAPTADOS ÀS NECESSIDADES DE CADA TRABALHO.

Fresas para limpeza de soldadura (sobre pedido).
Para eliminar el reborde o cordón de soldadura en las hojas y marcos de ventanas en PVC.
Perfiles compensados a 45° y adaptados a la necesidad de cada trabajo.

FRESAS PARA RETESTAR / CONTRA-PERFILAR (A PEDIDO)
PARA RETESTAR TRAVESSAS OBTENDO O CONTRA-PERFIL PARA UNIÕES A 90°

Fresas para retestar e contraperfilar (sobre pedido)
Para retestar y obtener el contraperfil en las uniones a 90°

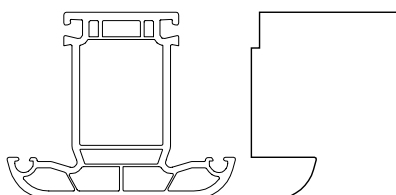
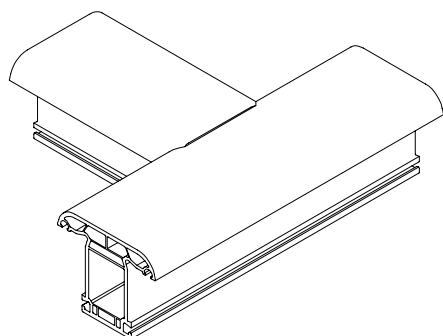

araujo&silva
ferramentas de corte

www.araujosilva.pt